

# 1,500 GALLON 2/C SEPTIC TANK

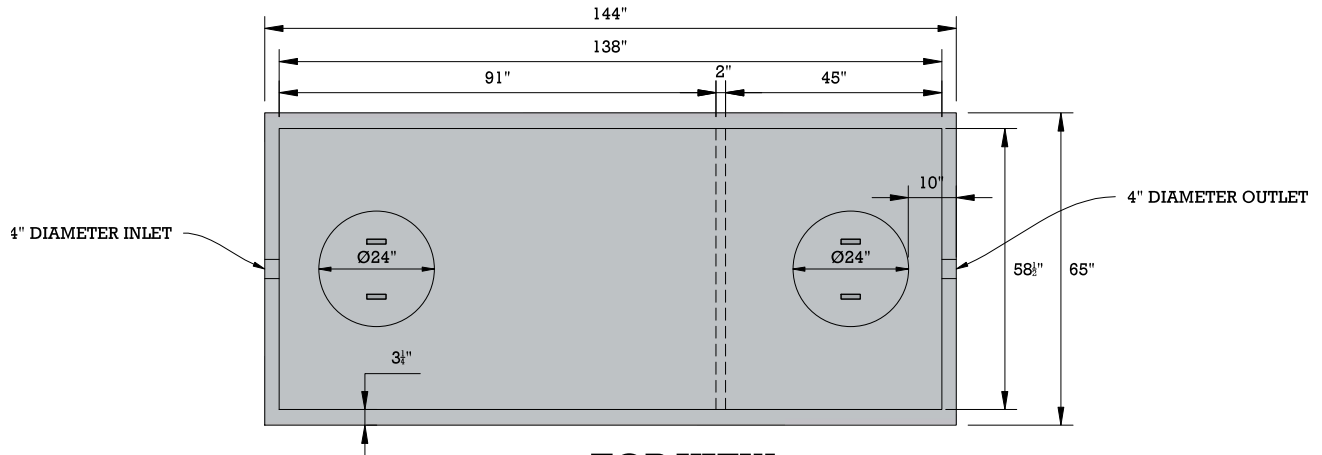

**TOP VIEW**

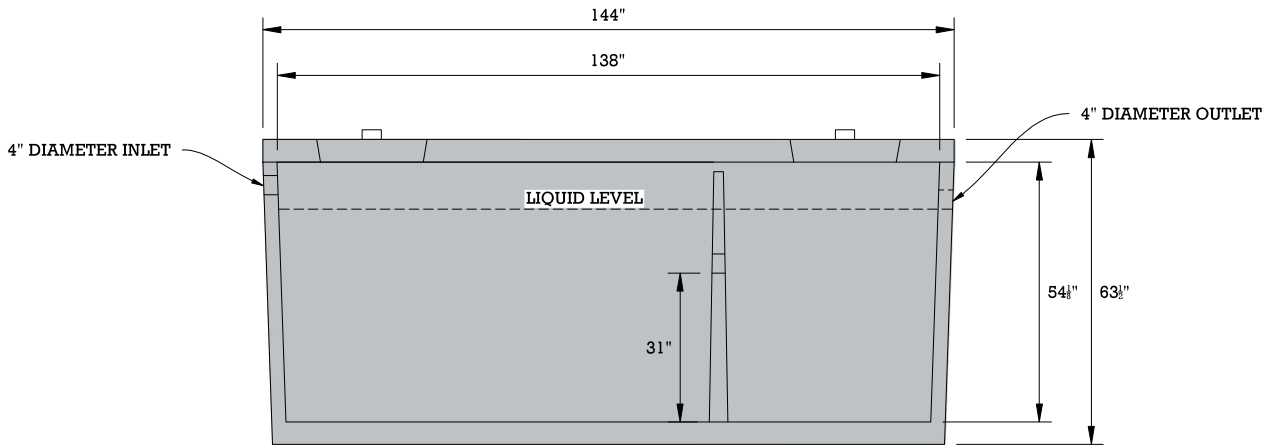

**SIDE VIEW**

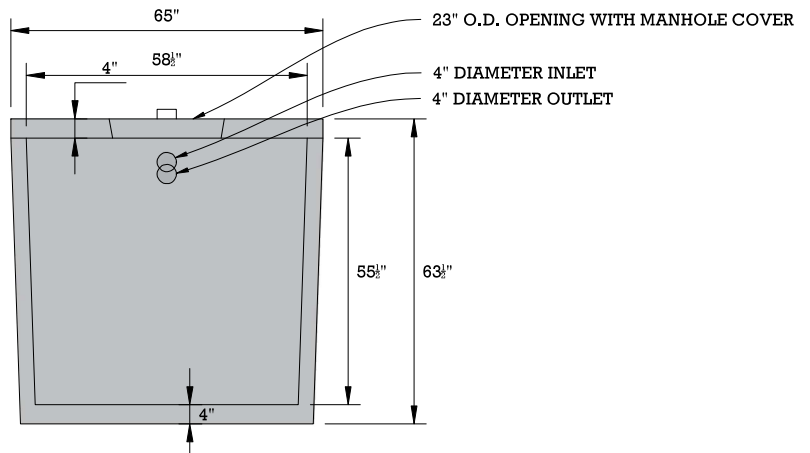

**FRONT VIEW**

WEIGHT (LBS)	SPECIFICATIONS
<b>14,300</b>	Concrete: 4000PSI @ 28 days
	Reinforcement: ASTM A615/A615M GRADE 60 ASTM A1064/A1064M-16B
	<ul style="list-style-type: none"> <li>• The tank is a monolithic pour (no mid seams).</li> <li>• Top Slab is sealed with prostick mastic.</li> <li>• The tank is designed to meet HS 20-44 loading requirements.</li> <li>• Reinforced lid - has optional PA inspection port.</li> <li>• Reinforced risers are available.</li> <li>• 3 optional inlets and 1 outlet location.</li> </ul>

**JMI**  
**Jamestown Macadam, Inc.**  
[www.jamestownmacadam.com](http://www.jamestownmacadam.com)  
 716-665-4504