

1500 GALLON 2 COMPARTMENT SEPTIC TANK

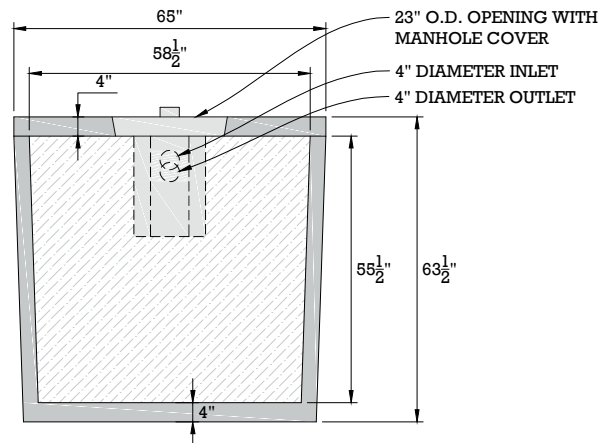
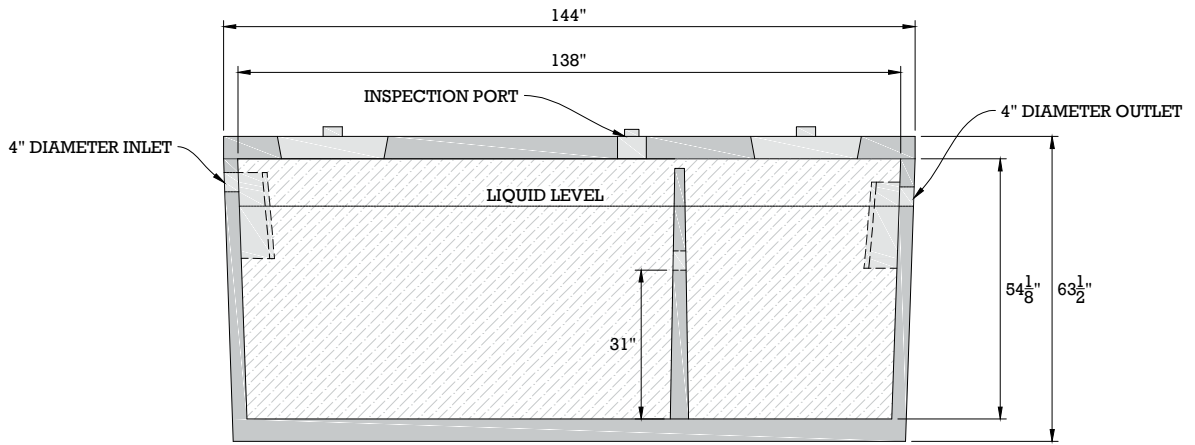
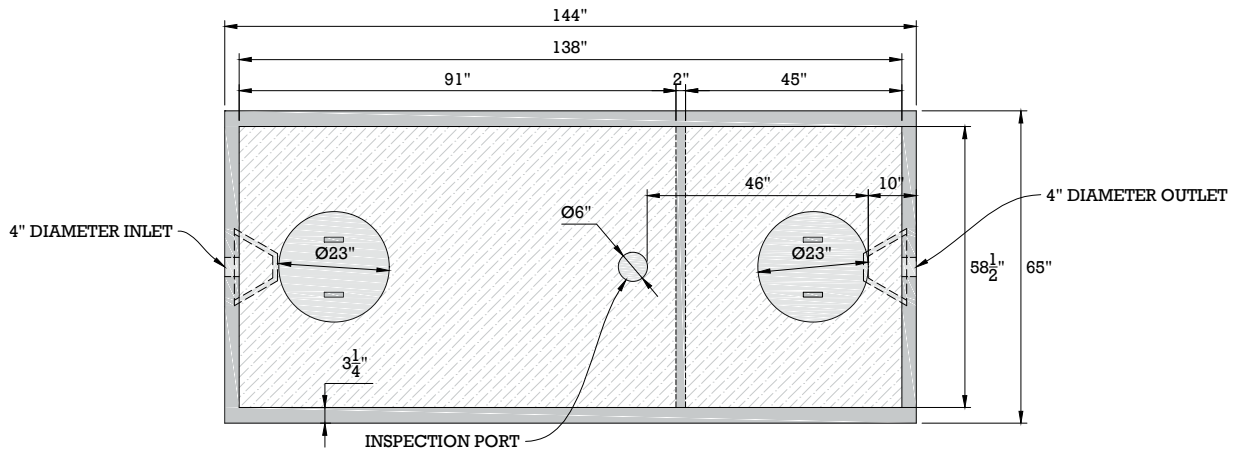

WEIGHT (LBS)	SPECIFICATIONS
11,600	Concrete: 4000PSI @ 28 days
	Reinforcement: ASTM A615/A615M GRADE 60 ASTM A1064/A1064M-16B
	<ul style="list-style-type: none"> • The tank is a monolithic pour (no mid seams). • Top Slab is sealed with prostick mastic. • The tank is designed to meet HS 20-44 loading requirements. • Reinforced lid - has optional PA inspection port. • Reinforced risers are available. • 3 optional inlets and 1 outlet location.

JMI
 Jamestown Macdam, Inc.
www.jamestownmacadam.com
 716-665-4504