

# 1500 GALLON SEPTIC TANK RISER

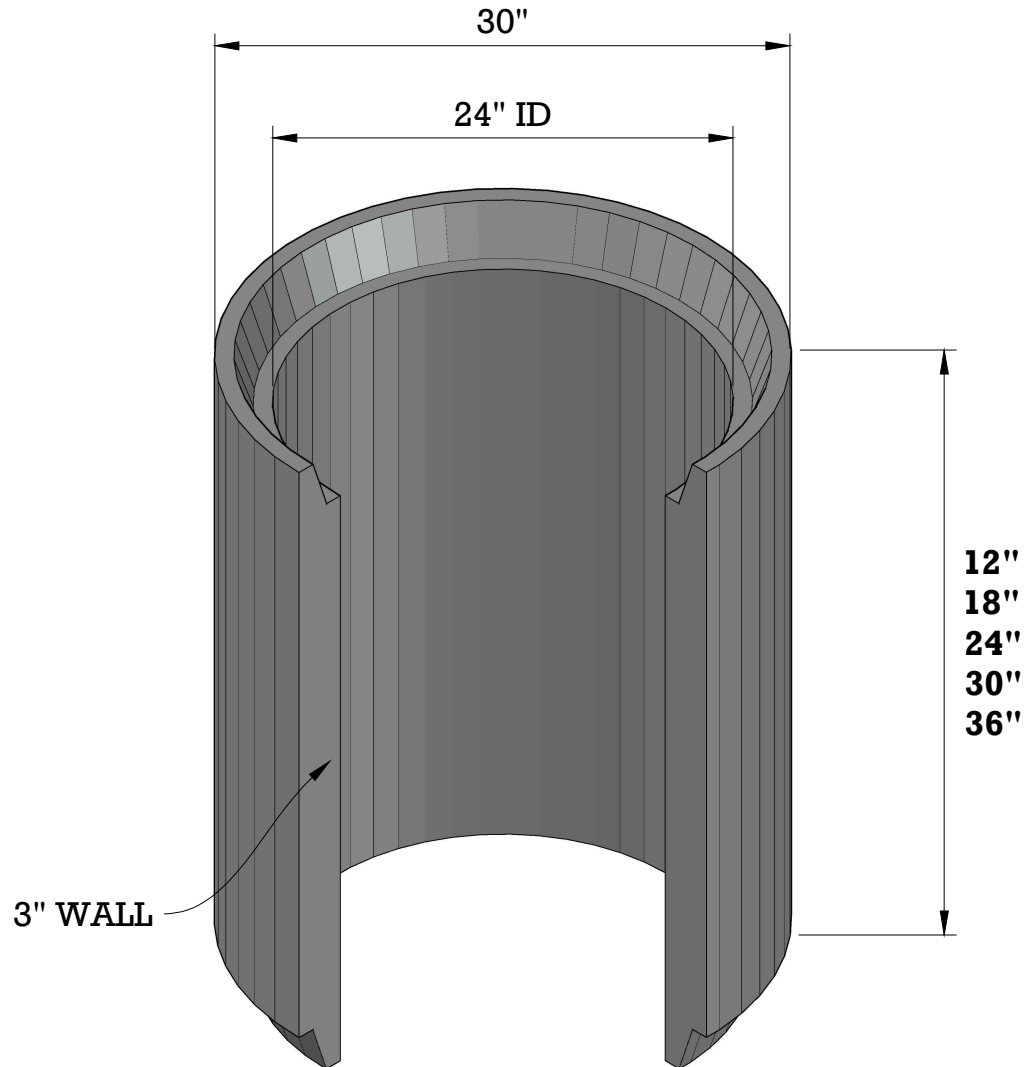

## ISOMETRIC VIEW

SIZE	WEIGHT (LBS)	SPECIFICATIONS
24"X8"	80	Concrete: 4000PSI @ 28 days
24"X12"	120	Reinforcement: ASTM A615/A615M GRADE 60 ASTM A1064/A1064M-16B
24" LID	80	<ul style="list-style-type: none"> <li>• The tank is a monolithic pour (no mid seams).</li> <li>• Top Slab is sealed with prostick mastic.</li> <li>• The tank is designed to meet HS 20-44 loading requirements.</li> <li>• Reinforced lid - has optional PA inspection port.</li> <li>• Reinforced risers are available.</li> <li>• 3 optional inlets and 1 outlet location.</li> </ul>
29" LID	80	

